

# 4-H HOME IMPROVEMENT

## UNIT 1 - YOUR ROOM

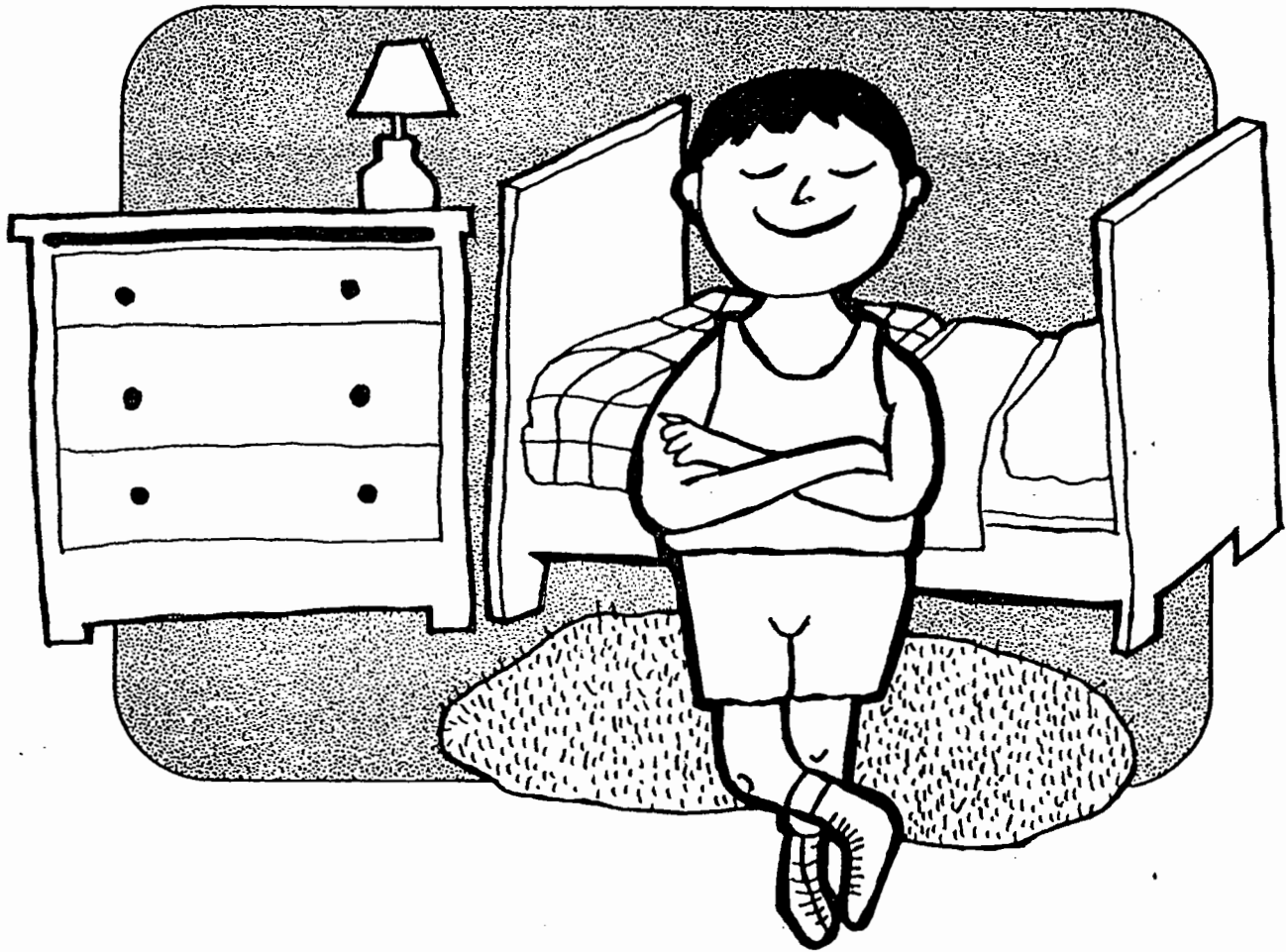

Florida Cooperative Extension Service  
Institute of Food and Agricultural Sciences  
University of Florida, Gainesville  
John T. Woeste, Dean for Extension

## TABLE OF CONTENTS

I THINGS TO MAKE .....	3	II THINGS TO DO .....	7
Wastebasket .....	3	Make the Bed .....	7
How to cover .....	3	Put Things Away .....	8
Laundry Bag .....	4	Make dividers .....	9
How to make .....	4	Make sliding tray .....	10
Covered Clothes Hangers .....	4	Look at your closet .....	10
How to cover .....	4	Finish step shelves .....	10
Wall Hangings .....	5	Dust Furniture .....	11
Bulletin Board .....	5	Make dust cloth .....	11
How to cover .....	5	Make dust mitts .....	11
Storage Boxes .....	6	Treat dust cloths and mitts .....	12
How to cover .....	6	Tips on Dusting Furniture .....	12
		Floor Care .....	12
		III RECORD .....	13

# HOME IMPROVEMENT

## Your Room—Unit I

You, as a 4-H girl or boy, can help your mother a great deal by keeping your room in order.

Your bedroom is your own private world—you can be proud of it when the gang drops in, if you do the things suggested in this project.

You do not need to have a room all your own to do this project.

Here are some of the things you should do during the year.

1. Make three or more items for your room. The following are some suggestions:
  - Drawer dividers for your dresser or chest of drawers*
  - Wastebasket*
  - Dust cloth*
  - Laundry bag*
  - Covered clothes hangers*
  - Wall hanging*
  - Bulletin board*
  - Any other item you wish to make, (discuss with Leader or Agent)*
2. Keep bed in order each day
3. Change bed linens each week
4. Put away clothes, both clean and soiled
5. Keep dresser or chest in order
6. Sweep floor and dust at least once a week
7. Keep your closet in order
8. Keep a record of what you do
9. Share with someone else something you learn in this project. This may be done by demonstration, talk, exhibit, or showing others your room and telling them what you learned.
10. Tell in writing what you have learned in the project

# Things To Make

## Wastebasket

Inexpensive wastebaskets may be made from 2 half-gallon ice cream cartons either painted or covered with wall paper, gift wrapping paper, self-adhesive paper, or cloth. Cartons may be purchased from ice cream manufacturers. You may have materials on hand that are suitable for this use.

Wastebaskets should not attract attention in a room. Select colors and patterns that are the same as the room or that go well with other colors in the room.

### HOW TO COVER

The covering should be cut wide enough to extend at least  $1\frac{1}{2}$  inch beyond the top and  $1\frac{1}{2}$  inch beyond the bottom of the carton, and long enough to go around it plus one inch for overlap where the ends join.

1. Lay the material you have cut to fit your carton on a table with wrong side up. Draw lines  $1\frac{1}{2}$  inch from the bottom and  $1\frac{1}{2}$  inch from the top of your material. (Figure 2).
2. Put glue or rubber cement on the material between pencil lines. Glue is not needed for self-adhesive paper.
3. Place the carton on the material so the top and bottom are even with the pencil marks (Figure 3).
4. Slowly turn the carton, pressing the paper to it. Begin at the top. Be sure to smooth out all air bubbles (Figure 4).
5. Apply glue to material that is to go under the

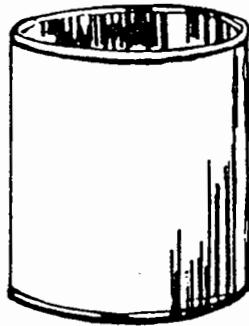

Fig. 1

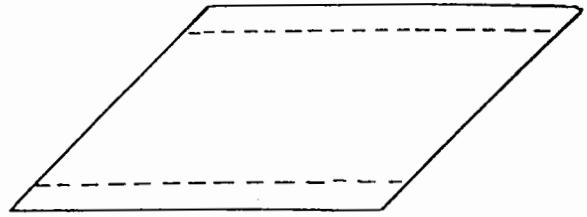

Fig. 2

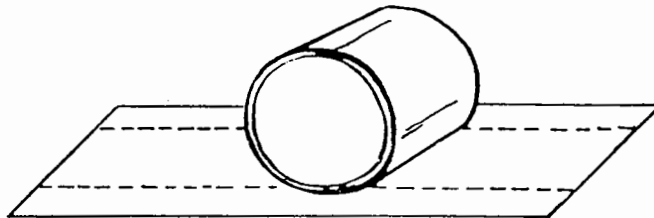

Fig. 3

bottom edge of the carton. Press in place. You will need to make several slits in the paper so it will fit smoothly (Figure 5).

6. Apply glue to the material that will go over the top edge of the carton. Be careful not to add so much glue that it runs down on the inside. It is easier to add a little extra near the edge than to wipe off excess.
7. You may or may not cover the outside bottom of your basket.
8. To protect the inside bottom of your wastebasket from becoming stained, cut a piece of heavy cardboard slightly smaller than the inside bottom. Cover it with a piece of aluminum foil. Cut foil large enough for a 2-inch fold under to the wrong side. Press in place. If it fits snugly, it will not fall out when you empty your wastebasket.

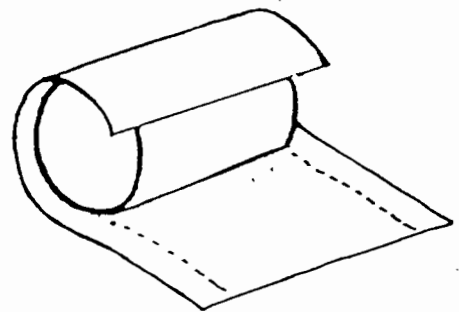

Fig. 4

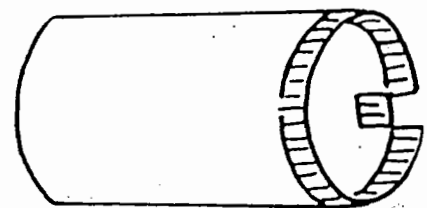

Fig. 5

9. To protect your wastebasket, you may finish it inside and out with clear varnish or shellac.

If you do not care to make a wastebasket but need one, shop around to see if you can find one that will look nice in your room. Before buying one, first compare the cost of a self-made one with the kind in stores.

## Laundry Bag

A small laundry bag for personal laundry is a convenient closet accessory. Materials for laundry bags should be washable. Use cotton prints, gingham, percale, denim, unbleached muslin or feed bags. You could use the same fabric used to make curtains or bedspread if it is sturdy and washable.

A suggested size for a laundry bag is about 17 inches wide and 26 inches long.

### Material needed

$\frac{3}{4}$  yard of 36-inch fabric  
 Wooden clothes hanger  
 Sewing tools: thread, tape measure, scissors, sewing machine.

### HOW TO MAKE

1. Fold material in half lengthwise
2. Stitch  $\frac{1}{2}$  inch from edge, along selvage, leaving 10 inches unstitched. (Figure 6).
3. Press seam open.
4. Refold the material so the seam is in the center—wrong side out.
5. Pin or baste bottom edges even and stitch a  $\frac{1}{2}$ -inch seam across the bottom. Back stitch or tie threads at each end of seam. (Figure 7).
6. With pencil, shape top of bag to fit the curve of the wooden hanger. Stitch along this line. Back stitch or tie threads at each end of seam. (Figure 8).
7. Turn bag right side out and press.
8. Put hanger in bag at top and you are ready to put it in your closet for use. (Figure 9).

*Remember: Never Leave Soiled Clothes in a Closet Very Long.*

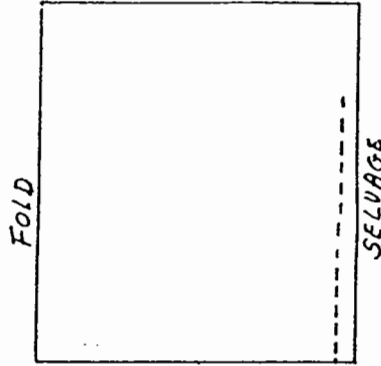

Fig. 6

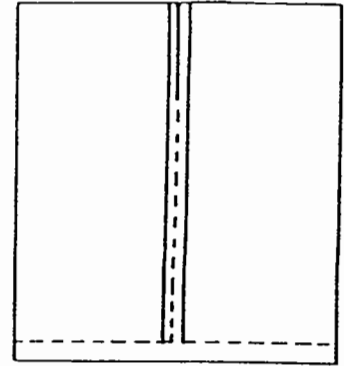

Fig. 7

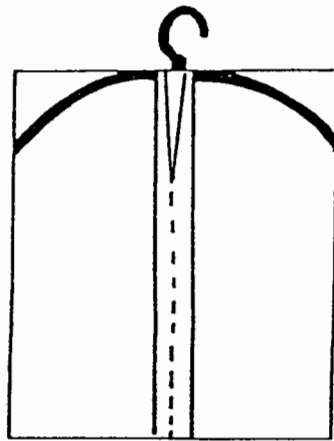

Fig. 8

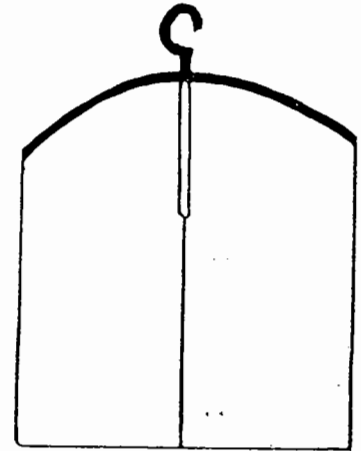

Fig. 9

## Covered Clothes Hangers

Covered clothes hangers prevent rust spots on your clothes. This is very important in our damp Florida climate, especially if your house is not air conditioned.

One good way to cover hangers is to use cotton rug yarn and do a blanket stitch around the wire. You will need about nine or ten yards of yarn for a hanger. A light color which goes well in your room will make your closet look nice. Dark colors may fade on your clothes.

### HOW TO COVER

1. Measure the needed length of yarn and roll it into a ball.
2. Tie one end to the cloth-

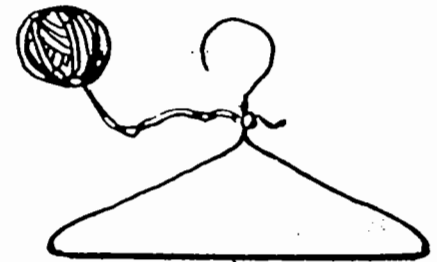

Fig. 10

es hanger just above where it begins to spread out on twisted part of hook (Figure 10).

3. Take the ball of yarn over the wire, down through the hanger, and back up between the wire and yarn (Figure 11).
4. Draw the yarn up tight

## Wall Hangings

This could be pictures, string paintings, fabric hangings, snapshot arrangements or others. Check with your Leader or Agent for ideas on making wall hangings.

## Bulletin Board

A bulletin board in your room gives you a place to pin or tack souvenirs, ribbons, cards, and other keepsakes. Before making a bulletin board, you need to decide where you want it and how large it should be.

The essential part of all bulletin boards is a piece of  $\frac{1}{2}$ -inch thick insulating board, wallboard, or cork. Remember, use a board into which you can put pins or thumb tacks.

You can cover the board with fabric. Monk's cloth, flannel or burlap are good fabrics to use.

An easy way to hang this type of bulletin board is to

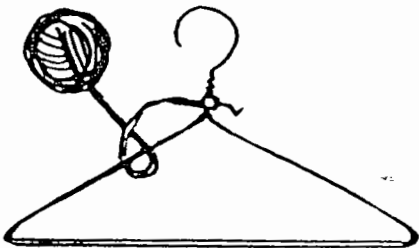

Fig. 11

toward the knot. Repeat this until you have gone all the way around the hanger. Tie yarn at end. Do not cover the part which goes over the rod in the closet.

Your first try may look rough. Cover several and see how you improve. This would make a nice gift for mother or a friend.

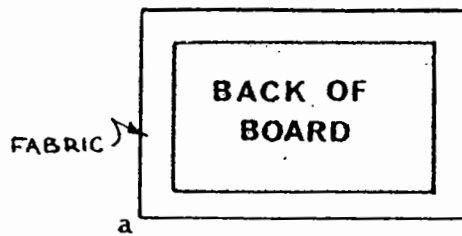

Fig. 12

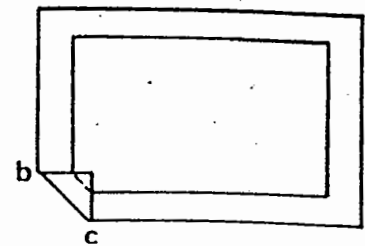

Fig. 13

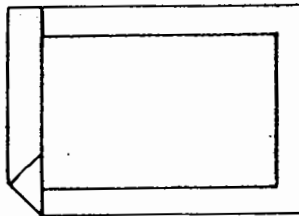

Fig. 14

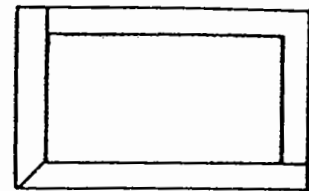

Fig. 15

drill two holes in the board about three inches from the top and sides. Use two bolts just long enough to go through the board and hold the bolt nut on the back side. If the screws are countersunk—that is, put in the board deep enough so that the heads are level with the board—they will not show through the fabric.

Use picture wire for hanging the bulletin board. Fasten the wire between the board and nuts.

### HOW TO COVER

1. Cut the fabric about six inches wider and longer than the board.
2. Spread the fabric flat on a table or clean floor with wrong side up. Place the front of the bulletin board down on the fabric, leaving an even margin all the way around like Figure 12.
3. Turn edges of fabric

over back of bulletin board. Fasten the fabric in the center on each side. Then turn the corners and edges as shown in Figures 13, 14 and 15.

The fabric may be fastened with tacks, masking tape, or staples.

You can miter the corners easily if the fabric extends the same amount on all sides:

Fold the corner A of the fabric over the corner of the board. If the fabric is very heavy, cut the tip off as shown on the dotted line. Fasten corner of fabric to board. (Figure 13).

Now bring corner B and edge into place as shown in Figure 14.

Next, fold corner C and edge into place as you did corner B. (Figure 15).

Miter all corners as you did corner A.

## Storage Boxes

Storage boxes can help keep your room in order. If they are covered or painted, they are more attractive. They may be covered with wall paper, gift wrapping paper, self-adhesive paper, or cloth.

### HOW TO COVER

1. Cut a piece of paper or cloth large enough to cover the bottom, all four sides, and enough to lap over the edges about one inch.
2. Lay covering on a flat surface, wrong side up. Spread glue on bottom of box. (Self-adhesive paper does not need glue.) Set box in center of covering material, long edges of box parallel to the long edges of covering material.
3. Spread glue on one end of box and pull covering material up over it. Smooth out bubbles by rubbing from bottom up toward top.
4. Crease along the bottom edge and cut on crease in toward and up to the corner of the box. Trim all but one inch from the side flaps. Spread glue on these one inch flaps and smooth in place (Figure 17).
5. Do other end in same way.
6. Spread glue on sides of box and smooth covering up over them (Figure 18).
7. Spread glue on edges sticking above box and smooth down inside of box.
8. Cover lid in the same way.

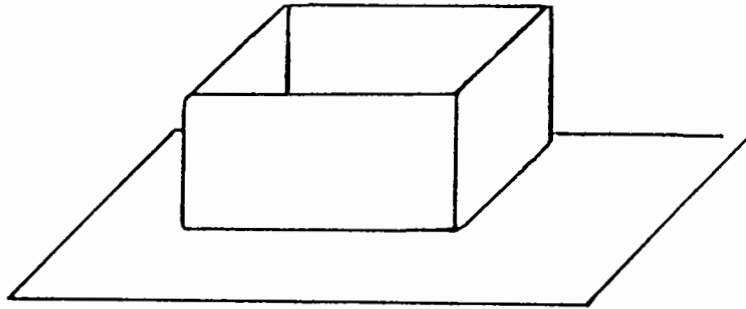

Fig. 16

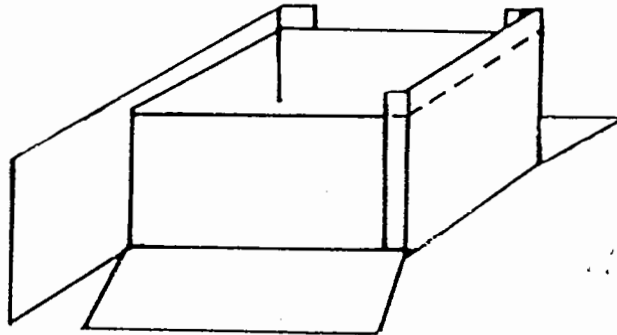

Fig. 17

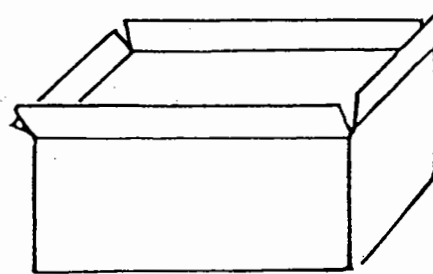

Fig. 18

# Things To Do

## Make The Bed

Each morning when you get up, turn back the covers and air the bed before making it.

About once a week change the bed linens and make the bed completely. In making your bed, try to keep from walking around the bed several times.

Try following these steps when making your bed. Start at the head of the bed and finish that corner before going to the next corner. This way, you go around the bed only once.

1. Stack bedding on chair or table in reverse order of use—2 pillows, 2 pillowcases, spread, blanket, 2 sheets, pad (Figure 19).
2. Start at corner nearest stacked bedding (Corner A, Figure 19).
3. Place pad over mattress and smooth.
4. Spread bottom sheet right side up, wide hem at top, using center fold as a guide.
5. Tuck about 5 inches of sheet under the mattress at head of bed. Miter corners (Figures 20, 21 and 22).

Here is how you miter a corner:

At the corner, hold the side of the sheet up so that the edge of the sheet is at right angles to the mattress. Lay upper part back over mattress (Figure 20).

Tuck in the part that hangs below the mattress from the corner to the hem (Figure 21).

Now drop the top edge which was lying on the bed and tuck that side tightly

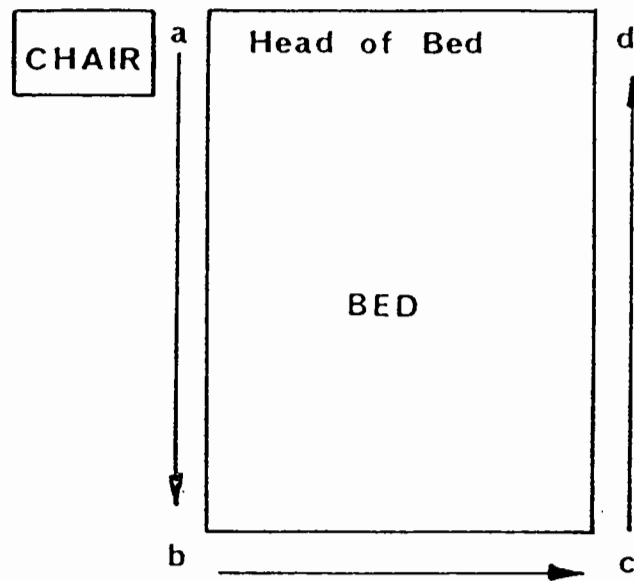

Fig. 19

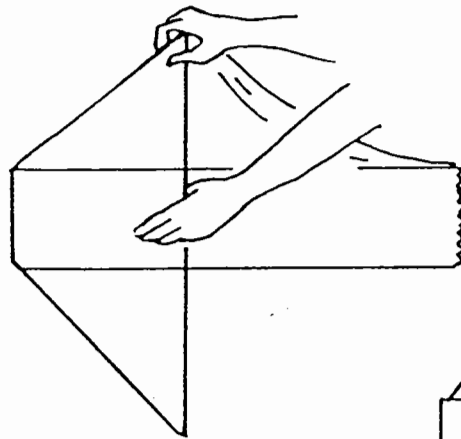

Fig. 20

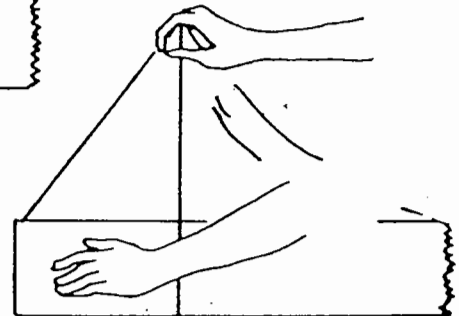

Fig. 21



Fig. 22

under the mattress (Figure 22).

6. Spread top sheet right side down using center fold as guide. Allow about 10 to 12 inches to turn back over blanket.
7. Place blanket on bed and smooth corner.
8. Fold top sheet over blanket.
9. Place spread with center fold as a guide. Fold top of spread about 18 to 20 inches back toward the foot.

10. Fluff pillow and smooth.
11. Put pillow in case. Hold one end of pillow close to body with the other end resting on the bed and draw on the case. Repeat for second pillow.
12. Place one pillow on the half of bed where you are working. The pillow should be near the headboard with the open end of pillow case at the edge of the bed. Overlap edge of pillow slightly on fold of spread.
13. Draw spread over pillow. Smooth underneath and tuck next to headboard.
14. Lay second pillow on first pillow for future use.
15. Move to foot on same side of bed to work (Corner B, Figure 19).
16. Pull lower sheet tight and tuck under end of mattress. Miter the cor-



Fig. 23

- ner (Figures 20, 21, and 22).
17. Pull top sheet in place.
18. Pull blanket in place.
19. Tuck sheet and blanket under the end of the mattress. Make half miter (Figure 23). For half miter, do not tuck edge of sheet under.
20. Smooth spread but do not tuck.
21. Move to the other corner of the foot of the bed (Corner C, Figure 19), and repeat steps 16-20. If desired, a toe pleat, (an extra horizontal fold in top sheet and blanket) can be made to provide extra foot room.

22. Finish Corner D as you did Corner A.

You may use fitted sheets on your bed. If you do, make the bed in the same order, finishing one side before going to the other.

**Bottom fitted sheets:** In putting on a bottom fitted sheet, slip the sheet pocket over the corner of the mattress. At the fourth corner you will need to lift the mattress and draw the sheet pocket over it. When the mattress is flat, the sheet is smooth and tight.

**Top fitted sheets:** In putting on a top fitted sheet, slip the sheet pockets over the corners of the mattress at the foot of the bed. Most fitted top sheets allow for a tuck or fold to be made across the bottom of the sheet. This gives more foot room when you are in bed.

### Put Things Away

Tossing clothes on the floor, the bed or a chair is rough on your clothes as well as the looks of your room.

Clothes which are to be worn again should be put on hangers or back in the dresser drawer. Soiled clothes should be put in the laundry bag or basket. Be sure to let damp

clothes dry before putting them in closet, dresser drawer, or laundry. This will help prevent mildew.

How does your dresser or chest look?

LIKE THIS?



OR

LIKE THIS?

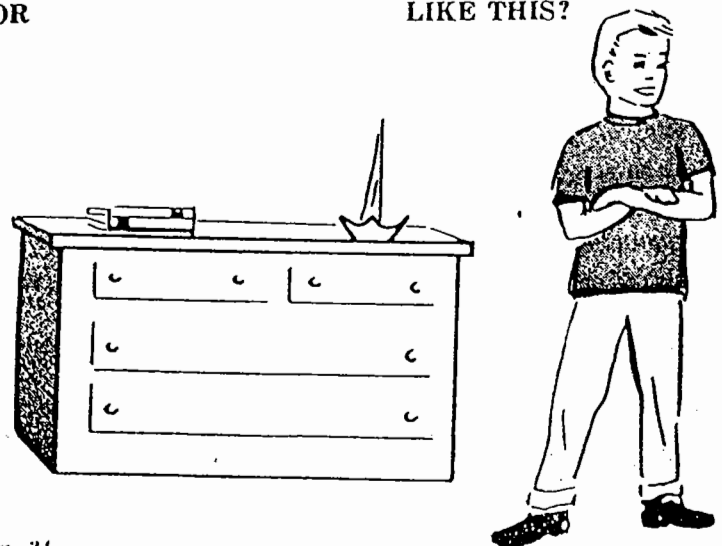

Fig. 24

Most people are collectors at heart. Are you? Do you have your most convenient storage spaces cluttered with things you seldom or never use? Why not make space for the articles you must have and use often? Discard those you do not need or use. Move the ones you seldom use to an out-of-the-way place. Free the drawers for articles you use all the time.

Well planned drawer storage can help keep your room looking nice.

It is a pleasure to open a drawer and find the article wanted without hunting around for it. Stored articles usually are in better condition when there is a definite place for them in the drawer and not all jumbled together.

Drawer dividers make a place for everything and keep everything in its place. You can buy or make dividers. The shape and size of the drawer and the articles you keep in it will determine the plan you use. No two persons are likely to use the same plan. Dividers help organize the contents of drawer storage space.

### Make Dividers

Cut a piece of paper the size of the bottom of the drawer for a pattern. Try placing articles in different ways to find the best place for them. Plan to store nearest the front of the drawer the things you use most often. After you have decided on the most convenient arrangement, mark on the paper the space needed for each section. When you have marked all sections you have your pattern.

You may get your dad or older brother to help you make the dividers.

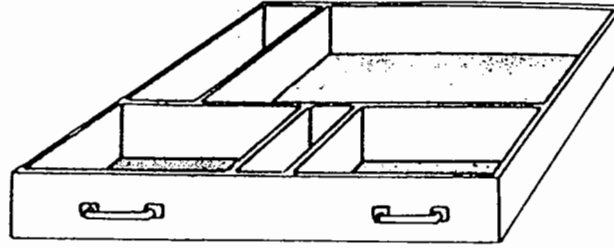

Fig. 25

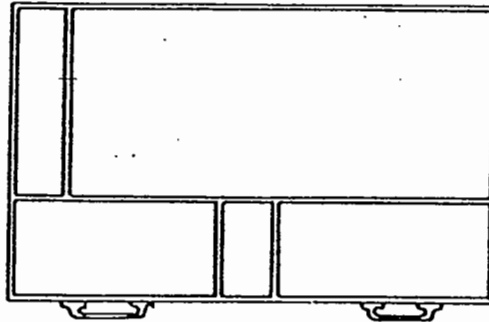

Fig. 26



Fig. 27

Inexpensive materials suitable for dividers are  $\frac{3}{8}$ -inch plywood or any other lightweight wood, masonite or heavy cardboard.

The height of the divider should be low enough for you to reach into each section easily. Measure the inside depth of drawer. Decide on best height for dividers;  $2\frac{1}{2}$  inches is a good height to use for drawers 4 to 5 inches deep.

Cut strips of divider material the lengths and widths needed according to measurements on your pattern. Cut slits where the dividers cross each other. These slits must be  $\frac{1}{4}$  inch longer than one-half the width of the divider, and  $\frac{1}{8}$  inch wider than the thickness of the strip of material. Fit strips together as planned. Hold them together with masking tape. Try the divider in drawer to see that it fits.

Finish the strips before permanently putting them together or fastening in drawer. The edges of wood should be sanded until they are smooth. You may wish to round the upper edges so they will have a finished look. The strips of masonite may be smoothed with sandpaper, too. Cardboard may have the rough edges bound with masking tape. This makes an attractive finish and adds strength. You may want to paint or varnish the dividers, or cover them with wallpaper, shelf paper or self-adhesive paper for a more finished appearance. If paper is used, it should be a color that does not fade when damp.

You can put wooden dividers together and hold in place in the drawer with small finishing nails. Small wooden

cleats or blocks are satisfactory for holding both wood and masonite dividers in place. Masking tape will hold all kinds of dividers in place, and is especially good to use for temporary storage.

Boxes make good dividers, too. They should be covered to protect articles and to make them more attractive. For directions on covering boxes see Page 6. Boxes should be the correct size for the things you are going to put in them.

### MAKE SLIDING TRAY

Trays that slide from front to back, or from side to side, are convenient in deep drawers and in drawers where small articles are stored. These trays slide on runners and are less than one-half the size of the drawer. In some

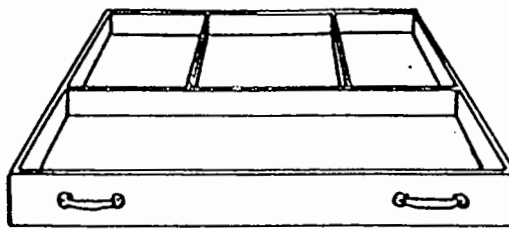

Fig. 28

cases two small trays might be used instead of one larger one.

Make runners on the sides or ends of the drawer of 1-inch by 1-inch stripping, quarter round or any small strips of wood. Smooth strips before fastening to drawer. Measure strips before fastening to drawer. Measure carefully the place for the runners. Nail or glue in place.

The bottom of the tray may be made of plywood, any light-weight wood or masonite. Determine the size and shape needed. Cut the bottom of the tray. Check to see if it fits and will slide easily. Make the sides of the tray from plywood or lattice stripping fit and nail together the strips at the corners. Then nail to the bottom section of the tray. Finish the same as you did the divider strips. The tray should be shallow enough not to interfere with the articles stored below it. A tray may have dividers in it to hold the stored articles in place.

You may use a box with small sections as a sliding tray. If box is smaller than size of tray needed, fasten it to a piece of plywood that fits into the drawer.

### Look At Your Closet

Do you like what you see? Is it neat or all jumbled up? Storage boxes in the closet can help you keep it looking

nice. Cover the boxes to make them more attractive. Directions for covering boxes are on page 6. You will need to label boxes so you know what is in them.

Step shelves for shoes or a shoe rack will help keep the closet in order. Step shelves can be made to look like Figure 29.

#### Suggested Size

Length .....24 inches  
 Height .....18 inches  
 Depth .....12 inches

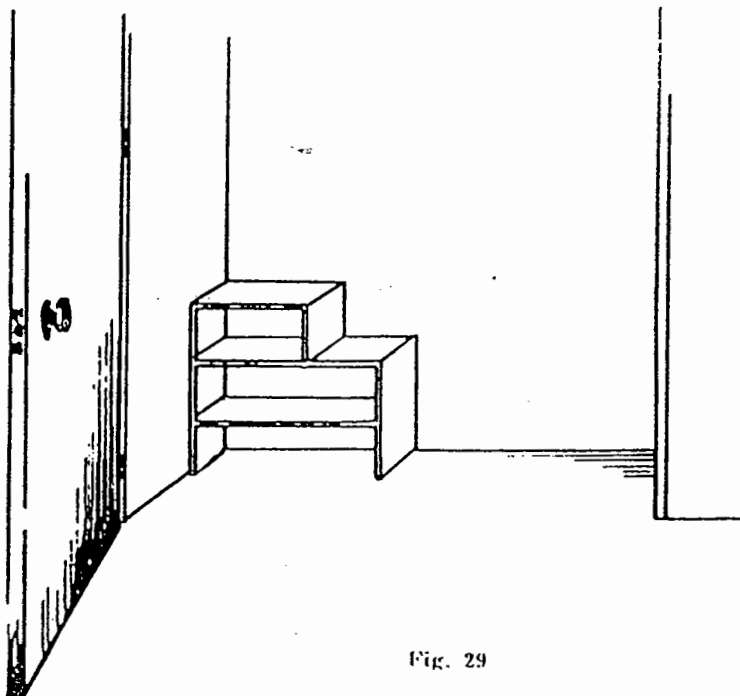

Fig. 29

### FINISHING STEP SHELVES

You will need to sand the wood smooth and apply some kind of finish to your step shelf. You may want to paint it the color of the inside of your closet or put a natural finish on it.

Ask your Leader or Agent to show you how to finish the step shelf.

Your closet should be arranged so you can find things easily and quickly.

1. Sort out garments not in season and put them

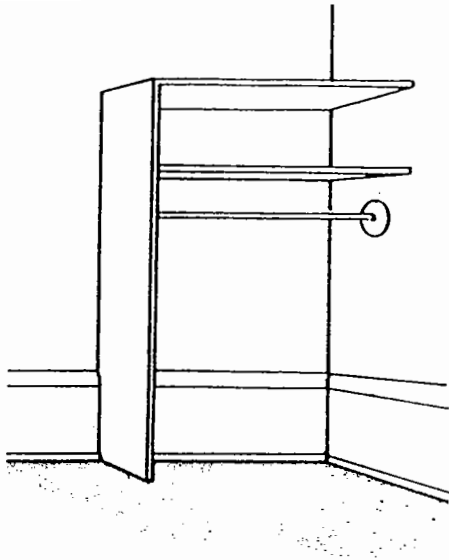

Fig. 30



Fig. 31

- away somewhere else or hang in back of closet.
2. Take out clothes you have outgrown.

3. Sort clothes by use such as out-of-door sports, dressy clothes, school clothes, etc.

4. Always hang up or put away clothes and other personal belongings in their proper places after using them.

### Dust Furniture

Dust furniture often, sometimes every day. Use a clean, soft, lint-free cloth or dust mitt. You can make and treat

your own dust cloths and mitts. When furniture has a wax finish or has been waxed, use an untreated cloth because oil softens and dulls wax.

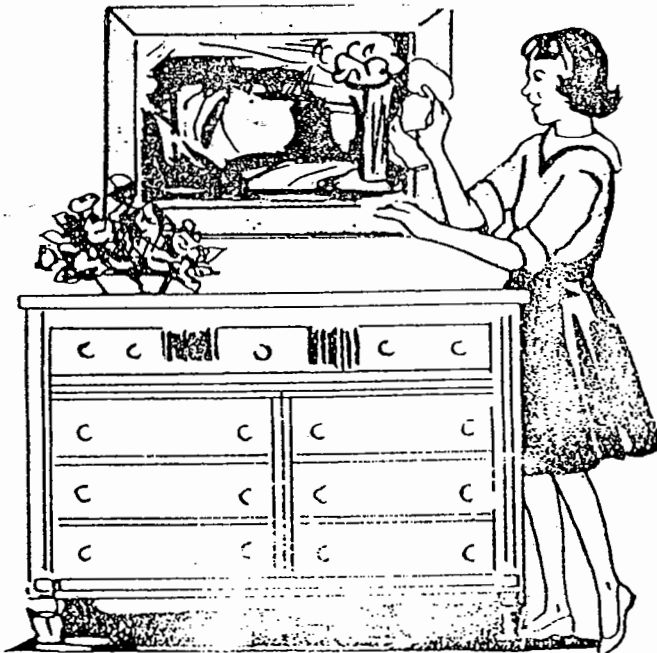

Fig. 32

### MAKE DUST CLOTHS

1. Cut or tear cloth into pieces of convenient size for handling. Use old sheets, towels, men's undershirts, or similar discarded articles.
2. Remove buttons, snaps, heavy seams, or anything which might scratch furniture finish.
3. Hem cloths so threads will not shed when you dust.

### MAKE DUST MITTS

1. Lay your hand flat on a piece of paper, fingers together and thumb stretched.
2. Trace around hand.
3. Allow  $\frac{1}{4}$  inch all the way around and cut out. This is your pattern.
4. Using the same kind of fabrics suggested for dust cloth, cut two pieces for each mitt. Sew together, using  $\frac{1}{4}$  inch seam. Leave top

open so hand will go in it.

5. Hem top. Turn so that seams are inside.

Make several mitts and treat them all at one time.

### TREAT CLOTHS AND MITTS

1. Mix together . . .
  - 1 quart hot water
  - 1 tablespoon soap flakes or synthetic detergent
  - 1 tablespoon turpentine or household ammonia
  - 2 tablespoons boiled linseed oil
2. Put cloths and mitts in solution and let stand about 30 minutes.
3. Wring out, dry and store in a jar or can with a tight-fitting lid.
4. Wash cloths when they become dirty.
5. Treat cloths again after they are washed.

### TIPS ON DUSTING FURNITURE

1. Use two cloths or mitts and dust with both hands. This saves time.
2. Start at one place and dust around the room.
3. Be sure to dust corners and grooves.
4. Take everything off the dresser or table, dust top, and then rearrange items.
5. Always use clean dust cloths.

### Floor Care

Floors need to have dust and sand removed often. Sand will scratch most floors. A vacuum cleaner is an excellent appliance for removing dust and sand. A soft broom or

hair brush is better for sweeping than a stiff broom.

If you are using a dry mop to dust floors, be sure it does not have a lot of oil on it as oil softens wax and causes it to have a dull look. A slightly damp mop is good for removing dust.

Always wipe up spills immediately for safety and to prevent a bigger cleaning job.

For more information on floor care ask your Leader or Agent for Extension Circular 226, "Selection and Care of Smooth Surface Floors."

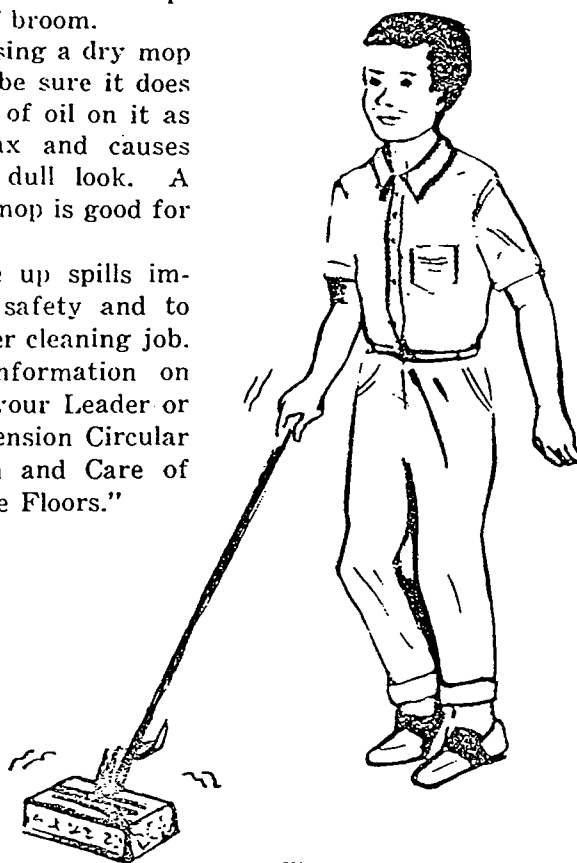

Fig. 33

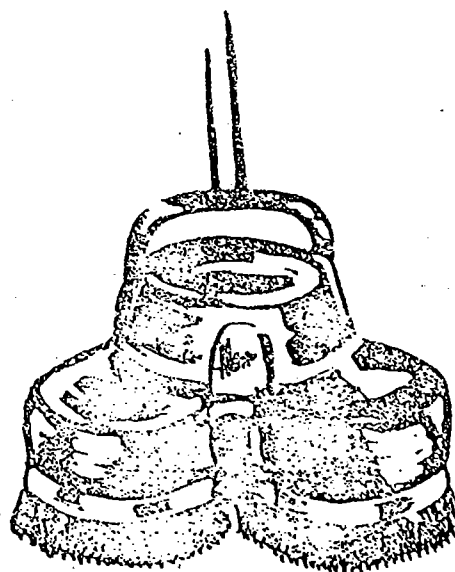

Fig. 31

The Double Brush for Polishing Floor



**I made or bought these articles for my room.**

<b>LIST</b>	<b>MADE</b>	<b>BOUGHT</b>
1.		
2.		
3.		
4.		
5.		
6.		
7.		
8.		

<b>I RECEIVED HELP FROM</b>	<b>WHAT THEY DID</b>

Part of your project was to share what you learned with someone else. This could be in the form of a Demonstration, Talks, Exhibits, or it could be showing people your room. Fill in the section or sections which you did.

I gave ..... demonstrations

<b>SUBJECT</b>	<b>WHERE GIVEN</b>	<b>NO. PEOPLE</b>
1.		
2.		
3.		
4.		
5.		

I gave ..... talks about home improvement

<b>SUBJECT</b>	<b>WHERE GIVEN</b>	<b>NO. PEOPLE</b>
1.		
2.		
3.		
4.		
5.		

I made an exhibit: Yes ..... (or) No .....

Place of Exhibit

**MY EXHIBIT INCLUDED:**

- 1.
- 2.
- 3.
- 4.
- 5.
- 6.
- 7.

**Any other ways you shared what you learned with others.**

**PICTURES OF THINGS I MADE FOR MY ROOM**

Snapshots would be excellent. However, you may draw pictures and show samples of materials used. (Add extra sheets if you need additional space for pictures)

## WHAT I LEARNED IN THIS PROJECT

(Write in your own words what you learned in carrying out this project.)

Keep the record in your project book. Ask your Leader or County Extension Home Economics Agent for a separate record book, to turn in for completing your project.

Prepared by:

Roberta H. Hall  
Home Improvement Specialist  
Florida Agricultural Extension Service  
64/1/20M 66/4/20M

References: Extension Circulars  
from Tennessee, Utah,  
and Virginia

This public document was promulgated at a cost of \$393.00, or 7.8 cents per copy, for use in Florida's educational 4-H and Youth Programs. 7 - 5M - 81

COOPERATIVE EXTENSION SERVICE, UNIVERSITY OF FLORIDA, INSTITUTE OF FOOD AND AGRICULTURAL SCIENCES, K. R. Tofertiller, director, in cooperation with the United States Department of Agriculture, publishes this information to further the purpose of the May 8 and June 30, 1914 Acts of Congress; and is authorized to provide research, educational information and other services only to individuals and institutions that function without regard to race, color, sex or national origin. Single copies of Extension publications (excluding 4-H and Youth publications) are available free to Florida residents from County Extension Offices. Information on bulk rates or copies for out-of-state purchasers is available from C. M. Hinton, Publications Distribution Center, IFAS Building 664, University of Florida, Gainesville, Florida 32611. Before publicizing this publication, editors should contact this address to determine availability.

